

Universal Shredding Machines



JBF 28/35

Field of application

depending on the machine type:

- CD/DVDs, computer hard drives and boards, carbon tapes
- paper, card boards, files completely filled
- tin and plastic cans
- PET bottles
- wood, wooden boxes, pallets
- domestic waste
- metal and plastic chips
- car/truck tires
- glass
- industrial waste
- cables and electronic waste
- plastic housings



Technology:

Knife shafts with knives that can be individually changed and resharpened. Connection between shafts and knives by means of multiple keys. Knives made of a long wearing knife-steel, laid out to cut metals, hardened.

The special machine construction with divided frame plates which allows to lift the complete knife shafts out of the machine for a quick exchange.

Low noise because the slow running cutting shafts are mounted on a sturdy, bolted machine housing.

Advantages:

Simple operation

through electronic control with reverse operation and automatic re-start

High throughput

The machine throughput and particle size of the shredded material is defined by knife width, knife diameter, knife form as well as the installed power of the machine

Highest safety for the operator

through limit switches on the doors and facing to prevent an unauthorized operation of the cutting unit. Emergency stop on the switch cabinet

Equipment

Manual pressure device and funnel cover, alternatively with limit switch control.

Infeed and exit conveyors as well as additional units like lifting and tilting unit, presses, press containers, suction devices can be integrated in the complete plant layout and machine concept.

JBF Maschinen GmbH

Flurstrasse 8
88367 Hohentengen

Phone: 07572 / 7641-0, Fax: 07572 / 7641-30

info@jbf-maschinen.de

www.jbf-maschinen.de



JBF 38/50

The shown machines are equipped with additional equipment. Technical changes and colour variances reserved.

Shredding machine JBF 28/35

Shredding machine JBF 38/50

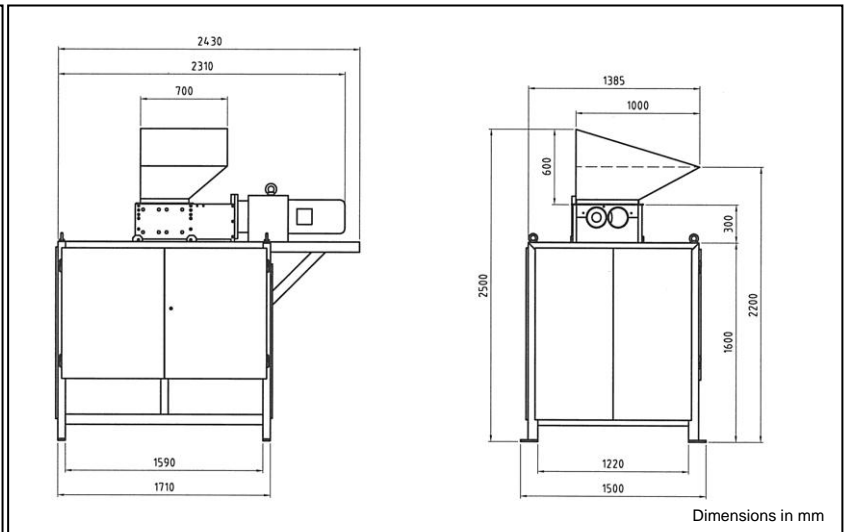
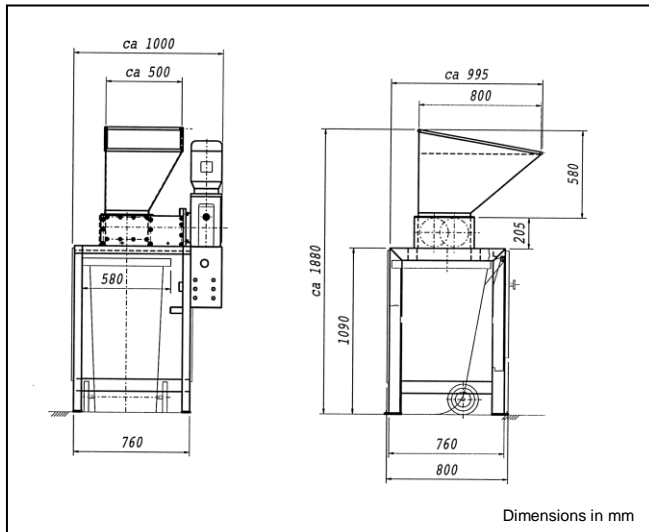

Technical data:

		JBF 28/35	JBF 35/35	JBF 38/50
Cutting zone	approx. mm	280 x 350	350 x 350	380x500
Knife width (standard/alternative)	mm	20 / 15 / 10	20 / 15 / 10	30 / 20
Drive (standard/alternative)	kW	2,2 / 3	2,2 / 3	7,5 / 9,2
Dimensions	l x w x h approx. mm	760x760x1900	760x760x1900	2500x1400x2500
Weight	kg	450	500	1350
Frame	for container/l	240	240	1100

Throughput in m³ / h

	JBF 28/35	JBF 35/35	JBF 38/50	JBF 48/50	JBF 54/60	JBF 60/60	JBF 100/60	JBF 150/60
Metal container	1	2	4	5	10	15	15	15
Plastic container	3	4	5	6	12	15	20	20
Mixed house waste	up to 3	up to 3,5	up to 6	up to 8	up to 10	up to 18	up to 20	up to 20
Wood waste	up to 1	up to 1,5	up to 4	up to 4	up to 7	up to 15	up to 10	up to 10

These specifications of the throughput are based on our experience and depends on the type of material, the material dimensions, how the material is transported into the machine as well as the technical layout of the machine.

Complete machine for the shredding of die-casting plastic waste consisting of:

- Lifting and tilting unit for customer container
- Conveyor device in the machine funnel
- shredding machine JBF 48/50, 7,5 kW
- Conveyor belt into container
- Central machine control with integration of all machine components
- Machine with special control with sensors for recognition of the container type
- Ultrasonic level control of the container
- Additional operation panel with all buttons



JBF Maschinen GmbH
Flurstrasse 8
D-88367 Hohentengen

Tel: 0049 (0)7572 / 7641-0, Fax: 0049 (0)7572 / 7641-30
e-mail: info@jbf-maschinen.de
Internet: www.jbf-maschinen.de

Technical modifications without notice.